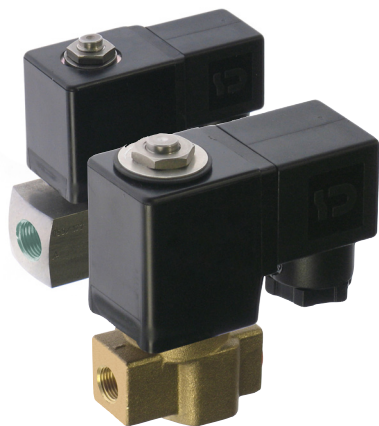

2/2-WAY SOLENOID VALVE, DIRECT OPERATED SEAT VALVE (HIGHER PRESSURES)

**Description:**

- 2/2-way valve
- seat valve
- direct operated
- female thread acc. to ISO228
- duty cycle 100% (VDE0580)
- any installation position, upright solenoid position recommended
- connector plug acc. to EN 175301-803

Range of application:

- viscosity 22mm²/s
- medium temperature -10°C up to +80°C
- ambient temperature: -10°C up to +35°C
- working pressure from 0bar
- no pressure difference required
- IP65 (with a professionally installed connector socket) according to DIN 40050
- for hot and cold water, oil and air

References:

For contaminated fluids insertion of a strainer is recommended

At operating state temperature the input power of a coil decreases by up to ca. 30% due to physical reasons.

Attention! The conditions imposed on the Ex approvals lead to reduction of the permissible standard temperature ranges in the cases of explosion protected solenoids.

Comments:

Voltage tolerance +10% / -10% at maximum pressure and standard ambient temperature. Please note the **flow direction** (marked with arrow on the body) during installation.

Higher pressure ranges with PTFE sealing are possible.

Other voltage, coil power or sealing on request! These can be found in the catalog under "spare parts and accessories". Included is the **connector socket GS02 (28x28mm)**. Further connector socket can be found in the catalog under square parts and accessories. **Higher protection class** than IP65 with special coils and connector sockets are possible on request.

Threads according to EN 228: It describes the threaded connection of a parallel male thread with a parallel female thread and is marked with "G".

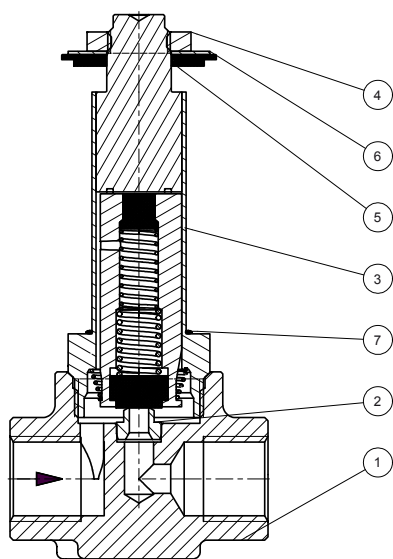

pos.	part	brass		stainless steel		optional material	
1	body	brass	A	1.4305	O	red brass	B
2	seat nozzle	1.4305		1.4305			
3	complete tube (incl. sealing)	FKM	V	FKM	V	EPDM* PTFE*	E T
5	sealing disc	FKM		FKM		EPDM PTFE	
7	o-ring	FKM		FKM		EPDM PTFE	

Wear parts (can vary depending on the valve design):

- Pos. 3: complete tube
- solenoid
- connector socket

For details about the order code see "Order information". An overview of the complete material code you can find at the beginning of each product section of the product catalogue.

***Other medium temperature** for optional sealing possible!

options:

- NO: opened in rest position
- HA: manual override
- AA: plunger spot
- OF: free of oil and grease
- BU: free of non-ferrous metal
- CV: chemically nickel plated body
- NPT: pipe thread ANSI B 1.20.1
- explosion protection acc. to ATEX: Ex II 2G EEx m II T4
Ex II 2G EEx em II T4
Ex II 2G EEx md II cT4, T5 or T6

2/2-WAY SOLENOID VALVE, DIRECT OPERATED SEAT VALVE (HIGHER PRESSURES)

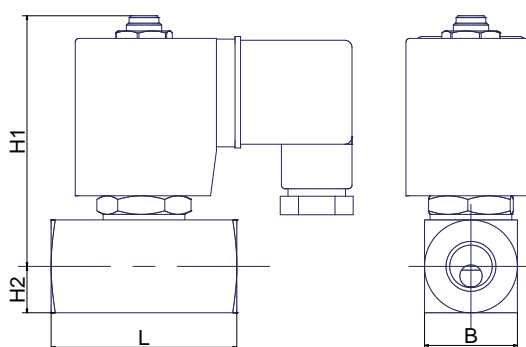
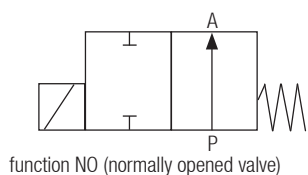
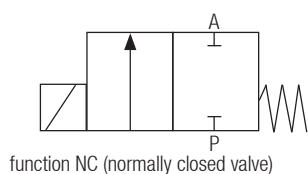

solenoid power:

type	AC*	DC
G03	24VA / 15VA	11W
G04	43VA / 24VA	18.5W
G20	9VA	10W

match code	size [inch]	no- minal size [mm]	working pressure [bar]			L [mm]	H1 [mm]	H2 [mm]	B [mm]	weight [kg]	CV** [m³/h]	
			min.	max. AC / DC								
				NC (G03)	NO (G04)							ATEX (G20)
GMV5200-01xx10-x-x	1/8	1	0	90	90	90	40	67.5	12.5	25	0.6	0.06
GMV5200-01xx15-x-x	1/8	1.5	0	85	40	90	40	67.5	12.5	25	0.6	0.09
GMV5200-01xx20-x-x	1/8	2	0	40	22	55	40	67.5	12.5	25	0.6	0.13
GMV5200-01xx25-x-x	1/8	2.5	0	22	14	28	40	67.5	12.5	25	0.6	0.16
GMV5200-01xx30-x-x	1/8	3	0	15	10	20	40	67.5	12.5	25	0.6	0.2
GMV5200-01xx40-x-x	1/8	4	0	8	on request	10	40	67.5	12.5	25	0.6	0.35
GMV5200-01xx50-x-x	1/8	5	0	5	on request	6	40	67.5	12.5	25	0.6	0.5
GMV5200-01xx60-x-x	1/8	6	0	4	on request	5	40	67.5	12.5	25	0.6	0.75
GMV5200-02xx10-x-x	1/8	1	0	90	90	90	40	67.5	12.5	25	0.6	0.06
GMV5200-02xx15-x-x	1/4	1.5	0	85	40	90	40	67.5	12.5	25	0.6	0.09
GMV5200-02xx20-x-x	1/4	2	0	40	22	55	40	67.5	12.5	25	0.6	0.13
GMV5200-02xx25-x-x	1/4	2.5	0	22	14	28	40	67.5	12.5	25	0.6	0.16
GMV5200-02xx30-x-x	1/4	3	0	15	10	20	40	67.5	12.5	25	0.6	0.2
GMV5200-02xx40-x-x	1/4	4	0	8	on request	10	40	67.5	12.5	25	0.6	0.35
GMV5200-02xx50-x-x	1/4	5	0	5	on request	6	50	67.5	12.5	25	0.6	0.5
GMV5200-02xx60-x-x	1/4	6	0	4	on request	5	50	67.5	12.5	25	0.6	0.75

*solenoid power for AC: listed are the pick-up power and the holding power.

**CV value: The nominal flow rate CVs acc. to VDI/VDE 2173 shows the water quantity in cubic meter per hour with the valve fully opened, $\Delta p=1$ and the water temperature between 5°C and 30°C.

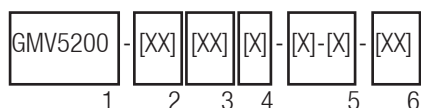

Order information:

1: type: GMV5200

2: connection size: 01-02 (see table)

3: materials:

- 1. digit: body material
A=brass
O=stainless steel
- 2. digit: sealing
V=FKM (standard)
E=EPDM
T=PTFE

4. nominal size in 1/10mm (see table)

5: operation:

- 1. digit (3 digits): specification solenoid type (see table / options)
- 2. digit: specification voltage:
0: 230V AC
1: 24V DC
2: 110V AC (on request)
Other voltage on request.

6: options (see "options")

Please ask for field specifications that are not listed in this data sheet.

Before installation please consider the installation and maintenance manual, especially the safety indications!

Heating and power of solenoid coils

default solenoid valves are designed for continuous operation (100% ED = power-on time) under normal operating conditions. The pulling force of a solenoid coil is basically influenced by three elements:

- the self-heating of the magnet coil
- the medium temperature
- the ambient temperature

Solenoid coils are by default designed for a maximum ambient temperature of +35 °C. This specification applies for the maximum allowable operating pressure specified in the data sheet of the corresponding valve, 100% duty cycle and a medium temperature of +80 °C.

A higher ambient temperature is possible, when lower values are applied for the other influencing parameters. When the max. operation pressure and max. ambient temperature of +50 °C is given the medium temperature is not allowed to be higher than max. +50 °C. In addition to that, deviations from the default design temperature range are possible, e.g. when temperature coils or other constructive measures are used. Please contact the MIT headquarters to discuss the specific application.

More precise specifications and technical data with regard to the operating conditions can be found in the data sheets of the solenoid coils and the solenoid valve regarded. Please observe that the surface temperature of a permanently loaded coil can amount up to +120 °C, solely by the self-heating of the coil. The power consumption of our default solenoid valves was calculated to DIN VDE 05820 for a coil temperature of +20 °C.