

## 2/2-WAY SOLENOID VALVE, DIRECT OPERATED SEAT VALVE (ECO)



## Description:

- 2/2-way valve
- seat valve
- direct operated
- female thread acc. to ISO228
- duty cycle 100% (VDE0580)
- any installation position, upright solenoid position recommended
- brass with low lead content

## Range of application:

- viscosity 22mm<sup>2</sup>/s
- medium temperature -10°C up to +130°C
- ambient temperature: -10°C up to +35°C
- working pressure from 0bar
- IP65 (with a professionally installed connector socket) according to DIN 40050
- for hot and cold water, oil and air

## References:

For contaminated fluids insertion of a strainer is recommended

At operating state temperature the input power of a coil decreases by up to ca. 30% due to physical reasons.

**Attention!** The conditions imposed on the Ex approvals lead to reduction of the permissible standard temperature ranges in the cases of explosion protected solenoids.

## Comments:

Please note the **flow direction** (marked with arrow on the body) during installation. **Voltage tolerance +10% / -10%** at maximum pressure and standard ambient temperature.

Other voltage, coil power or sealing on request! Included is the **connector socket GS01 (21x28mm)**. Further connector sockets can be found in the catalog under "square parts and accessories". **Higher protection class** than IP65 is possible with special coils and connector sockets.

**Threads according to EN 228:** It describes the threaded connection of a parallel male thread with a parallel female thread and is marked with "G".

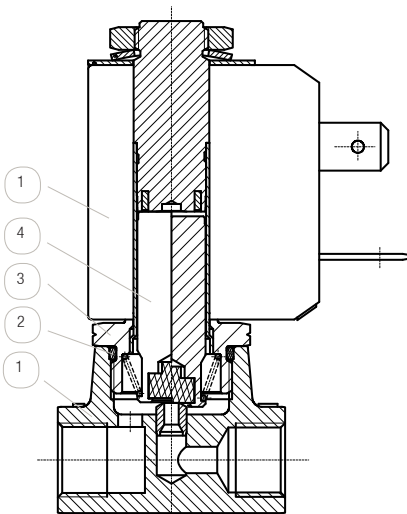

pos.	part	brass		optional material	
1	body	CW719R EN 12165	A		
3	tube				
4	plunger and sealing	stainless steel and FKM	V	stainless steel and EPDM	E
2	o-ring	FKM		EPDM	
5	solenoid				

## wear parts of sealing system:

- Pos. 2: o-ring

## wear parts of solenoid system:

- Pos. 3: tube
- Pos. 4: plunger and sealing
- Pos. 5: solenoid

An overview of the complete material code you can find at the beginning of each product section of the product catalogue.

\* Please note **different medium temperatures:**

- EPDM up to max. 120°C

## options:

- NO: opened in rest position up to nominal size 3mm
- OF: free of oil and grease
- CV: chemically nickel plated body
- HA: manual override
- NPT: pipe thread ANSI B 1.20.1

## 2/2-WAY SOLENOID VALVE, DIRECT OPERATED SEAT VALVE (ECO)

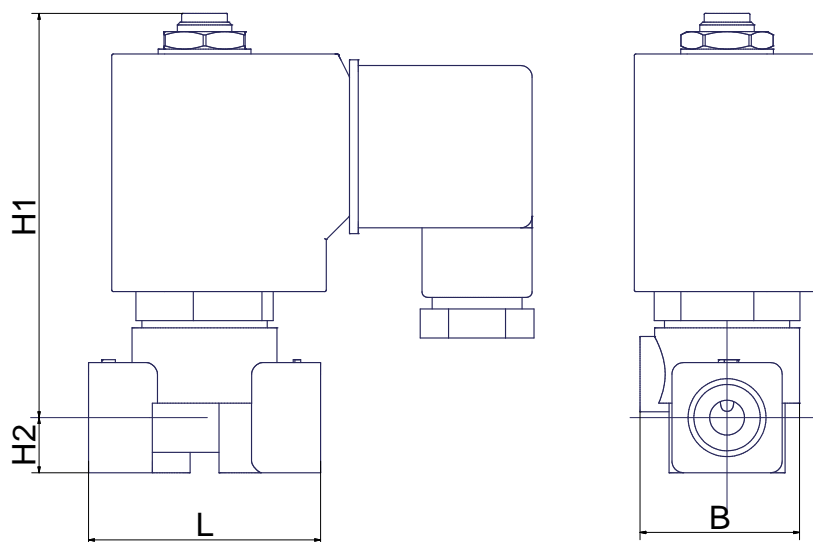
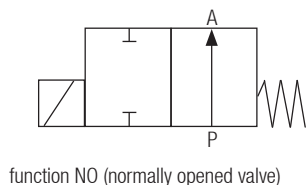
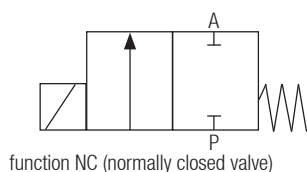

match code	size [inch]	nominal size [mm]	working pressure [bar]			L [mm]	H1 [mm]	H2 [mm]	B [mm]	weight [kg]	CV* [m <sup>3</sup> /h]	solenoid power	
			min.	max. AC	max. DC							AC*	DC
GMV2197-01Ax10-M01-x	1/8	1	0	30	28	30	58	7	18	0.15	0.03	16/10VA	7W
GMV2197-01Ax12-M01-x	1/8	1.2	0	25	22	30	58	7	18	0.15	0.042	16/10VA	7W
GMV2197-01Ax15-M01-x	1/8	1.5	0	22	18	30	58	7	18	0.15	0.06	16/10VA	7W
GMV2197-01Ax20-M01-x	1/8	2	0	18	9	30	58	7	18	0.15	0.102	16/10VA	7W
GMV2197-01Ax25-M01-x	1/4	2.5	0	13	3	30	58	7	18	0.15	0.138	16/10VA	7W
GMV2197-01Ax30-M01-x	1/4	3	0	8	1	30	58	7	18	0.15	0.18	16/10VA	7W

\*solenoid power for AC: listed are the pick-up power and the holding power.

\*CV value: The nominal flow rate CVs acc. to VDI/VDE 2173 shows the water quantity in cubic meter per hour with the valve fully opened,  $\Delta p=1$  and the water temperature between 5°C and 30°C.

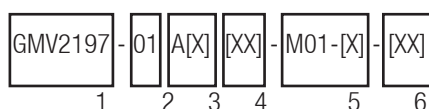

## Order information:

1: type: GMV2197

2: connection size: 01-(G1/8")

## 3: materials:

- 1. digit: body material  
A (brass)
- 2. digit: sealing  
E=EPDM  
V=FKM (standard)

4. nominal size in 1/10mm (see table)

## 5: operation:

- specification of the solenoid type: M01
- specification of voltage:  
0: 230V AC  
1: 24V DC  
Other voltage on request.

## 6: options (see "options")

Please ask for field specifications that are not listed in this data sheet.

Before installation please consider the installation and maintenance manual, especially the safety indications!

## Heating and power of solenoid coils

default solenoid valves are designed for continuous operation (100% ED = power-on time) under normal operating conditions. The pulling force of a solenoid coil is basically influenced by three elements:

- the self-heating of the magnet coil
- the medium temperature
- the ambient temperature

Solenoid coils are by default designed for a maximum ambient temperature of +35 °C. This specification applies for the maximum allowable operating pressure specified in the data sheet of the corresponding valve, 100% duty cycle and a medium temperature of +130 °C.

A higher ambient temperature is possible, when lower values are applied for the other influencing parameters. When the max. operation pressure and max. ambient temperature of +50 °C is given the medium temperature is not allowed to be higher than max. +50 °C. In addition to that, deviations from the default design temperature range are possible, e.g. when temperature coils or other constructive measures are used. Please contact the MIT headquarters to discuss the specific application.

More precise specifications and technical data with regard to the operating conditions can be found in the data sheets of the solenoid coils and the solenoid valve regarded. Please observe that the surface temperature of a permanently loaded coil can amount up to +120 °C, solely by the self-heating of the coil. The power consumption of our default solenoid valves was calculated to DIN VDE 05820 for a coil temperature of +20 °C.