

## 2/2-WAY SOLENOID VALVE WITH FLANGES, FORCE PILOT OPERATED



## References:

For contaminated fluids insertion of a strainer is recommended

At operating state temperature the input power of a coil decreases by up to ca. 30% due to physical reasons.

**Attention!** The conditions imposed on the Ex approvals lead to reduction of the permissible standard temperature ranges in the cases of explosion protected solenoids.

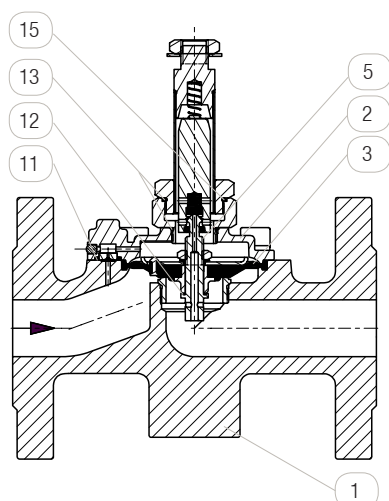

## Description:

- 2/2-way valve in flanged design
- diaphragm design
- force pilot operated
- face-to-face length acc. to EN558-1, series 1
- duty cycle 100% (VDE0580)
- installation position: with upright solenoid
- flanges acc. to EN1092-1 PN16/40
- adjustable close muting from DN32
- types in grey cast iron and cast steel for corrosion protection with thick-film passivation
- connector plug acc. to EN 175301-803 or terminal box (depending on the coil design)

## Comments:

**Voltage tolerance +10% / -10%** with maximum pressure and standard ambient temperature. Please note when installing the flow direction (marked with arrow on body).

Valves with ANSI flanges available.

Other voltage, coil power or sealing on request! These can be found in the catalog under "spare parts and accessories". Included in delivery is the **connector plug acc. to EN 175301-803**. Further connector socket can be found in the catalog under square parts and accessories. **Higher protection class** than IP65 with special coils and connector sockets are possible on request.

pos.	part	grey cast iron		cast steel		stainless steel	options	
1	body	EN-GJL-250 thick-film passivated	L	GP240GH thick-film passivated	K	1.4581	0	
2	cover	brass		brass		1.4581		
3	diaphragm	NBR	B	NBR	B	NBR	B	FKM EPDM V E
4	pilot seat	1.4104		1.4104		1.4104		
11,12	o-ring / sealing	NBR		NBR		NBR		FKM EPDM V E
13,15	plunger	1.4104		1.4104		1.4104		

## wear parts\*:

- diaphragm
- spring
- O-ring (RS)
- O-ring for pilot hole
- O-ring (RS)
- tube
- plunger
- plunger spring
- solenoid
- connector socket

\*Wear parts can vary depending on the valve design.

An overview of the complete material code you can find at the beginning of each product section of the product catalogue.

## options:

- NO: opened in rest position
- HA: manual override
- TH: high temperature design up to 130°C
- OF: free of oil and grease
- BU: free of non-ferrous metal
- PS: position indicator (from DN20)
- explosion protection acc. to ATEX Ex II 2G EEx em II T4
- RS: adjustable close muting up to DN25 (from DN32 as standard)
- AA: sealed plunger spot

## 2/2-WAY SOLENOID VALVE WITH FLANGES, FORCE PILOT OPERATED

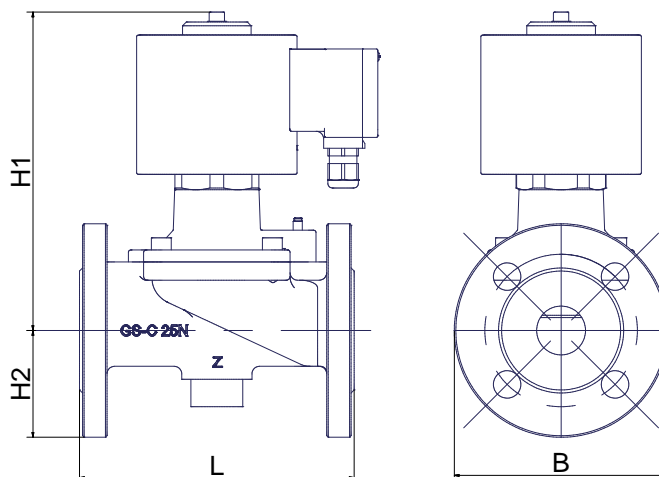
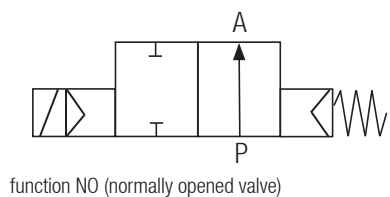
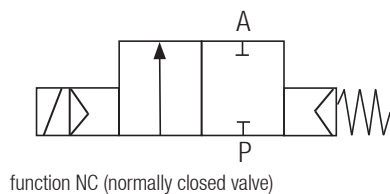

match code	size [inch]	nominal size [mm]	working pressure [bar]		L [mm]	H1 [mm]	H2 [mm]	B [mm]	weight [kg]	CV* [m <sup>3</sup> /h]	solenoid power	
			min.	max.							AC*	DC
			FMV2700-52-3xx150-G07-x	DN15							15	0
FMV2700-53-3xx200-G07-x	DN20	20	0	16	150	130	52.5	105	4	10.8		25W
FMV2700-54-3xx250-G07-x	DN25	25	0	16	160	130	57.5	115	4.4	13		25W
FMV2700-55-3xx320-G08-x	DN32	32	0	10	180	195	70	140	8.1	n/a	with separate rectifier	30W
FMV2700-55-3xx320-G09-x	DN32	32	0	16	180	219	70	140	9.3	30		46W
FMV2700-56-3xx400-G08-x	DN40	40	0	10	200	195	75	150	9	n/a		30W
FMV2700-56-3xx400-G09-x	DN40	40	0	16	200	219	75	150	10.1	32		46W
FMV2700-57-3xx500-G09-x	DN50	50	0	16	230	229	82.5	165	12.5	45		46W

\*solenoid power for AC: listed are the pick-up power and the holding power.

\*\*CV-value: The nominal flow rate CV according to VDI / VDE 2173 is the water quantity in m<sup>3</sup>/h for the flow direction with the pressure difference  $\Delta p = 1$  bar and a medium temperature between +5°C and 30°C.

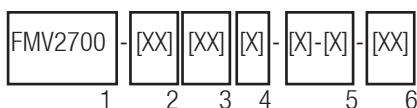

## Order information:

1: type: FMV2700

2: connection size: 52-57 (see table)

## 3: materials:

- 1. digit: body material L=grey cast iron  
K=cast steel O=stainless steel
- 2. digit: sealing B=NBR (standard) V=FKM  
E=EPDM

4. nominal size in 1/10mm (see table)

## 5: operation:

- 1. digit (3 digits): specification solenoid type (see table / options)
- 2. digit: specification voltage: 0: 230V AC  
1: 24V DC  
2: 110V AC (on request)  
Other voltage on request.

## 6: options (see "options")

Please ask for field specifications that are not listed in this data sheet.

Before installation please consider the installation and maintenance manual, especially the safety indications!

## Heating and power of solenoid coils

default solenoid valves are designed for continuous operation (100% ED = power-on time) under normal operating conditions. The pulling force of a solenoid coil is basically influenced by three elements:

- the self-heating of the magnet coil
- the medium temperature
- the ambient temperature

Solenoid coils are by default designed for a maximum ambient temperature of +35 °C. This specification applies for the maximum allowable operating pressure specified in the data sheet of the corresponding valve, 100% duty cycle and a medium temperature of +80 °C.

A higher ambient temperature is possible, when lower values are applied for the other influencing parameters. When the max. operation pressure and max. ambient temperature of +50 °C is given the medium temperature is not allowed to be higher than max. +50 °C. In addition to that, deviations from the default design temperature range are possible, e.g. when temperature coils or other constructive measures are used. Please contact the MIT headquarters to discuss the specific application.

More precise specifications and technical data with regard to the operating conditions can be found in the data sheets of the solenoid coils and the solenoid valve regarded. Please observe that the surface temperature of a permanently loaded coil can amount up to +120 °C, solely by the self-heating of the coil. The power consumption of our default solenoid valves was calculated to DIN VDE 05820 for a coil temperature of +20 °C.